

DENTALEZ
2020

DENTALEZ

A COMPANY TIMELINE

Aeras *INTELLIGENCE*

Columbia *DENTOFORM*

Forest *EQUIPMENT*

Nevin *WORKSTATIONS*

Ramvac *UTILITY*

Star *HANDPIECES*

Aeras
Compressors

Aeras
Dry Vacuums

Bison

Badger LF

Tanks

Wet Vacuums

Maintenance

OWL Touch

Remote Panels

Steel Frame
Stands

Master Water
Control Valve

Amalgam
Seperator

VACHECK
FLOWCHECK

SlugBuster

Warranty

Sales Teams

AERAS PRODUCT PLATFORM LAUNCHED

New embedded technologies enable your tools to communicate with each other and with you, making them more powerful, more efficient, and easier to maintain.

ACQUIRES FOREST DENTAL

Forest brings a portfolio of equipment focused on ergonomics, aesthetics and comfort. Offering a variety of color, surface and finish choices that present every practice an affordable solution to realize their vision.

OSPREY COMPRESSORS LAUNCHED

The industry's highest-output compressors that also produce clean, dry air with an innovative dual desiccant dryer system.

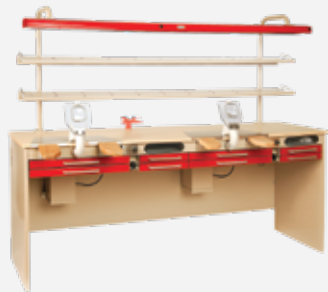

2007

ACQUIRES NEVIN LABS

Our vision for dental solutions expands outside the treatment room with the company that has built and installed more dental laboratory work stations and processing equipment in North America than all other manufacturers combined.

ACQUIRES RAMVAC

Two innovators join forces to offer a full spectrum of water-free dental vacuum systems designed for decades of reliability.



1990

ACQUIRES STAR DENTAL & COLUMBIA DENTOFORM

Three industry pioneers come together under one roof. Along with the J-Chair, their innovations include fiber optics, sonic scalers, and LubeFree™ ceramic handpieces.

FOUNDED & THE J-CHAIR LAUNCHED

DENTALEZ starts selling the first ever reclining treatment chair, which allows patients to sit back comfortably while providing dentists easy access, revolutionizing the industry.

1958



2020

Aeras



2018



Aeras
Compressors

Aeras
Dry Vacuums

Bison

Badger LF

Tanks

Wet Vacuums

Maintenance

OWL Touch

Remote Panels

Steel Frame
Stands

Master Water
Control Valve

Amalgam
Separator

VACHECK
FLOWCHECK

SlugBuster

Warranty

Sales Teams

Aeras

THE SMART WAY TO POWER YOUR PRACTICE



Feel confident knowing your utility equipment can be **monitored** & protected around the clock¹



Service provider can view up to **six months of data** to help diagnose potential issues¹



8-Year optional extended warranty*



Schedule remotely exactly when your **equipment powers up & down**¹



Get **automatic notification** when preventive maintenance is required¹

UTILITY
Aeras
Ramvac

ORDER ON PAGES 11-14

INTELLIGENT UTILITY
THAT MONITORS & COMMUNICATES

*Terms apply

¹Applies only if subscribing to monitoring service

Aeras
Compressors

Aeras
Dry Vacuums

Bison

Badger LF

Tanks

Wet Vacuums

Maintenance

OWL Touch

Remote Panels

Steel Frame
Stands

Master Water
Control Valve

Amalgam
Separator

VACHECK
FLOWCHECK

SlugBuster

Warranty

Sales Teams

INTELLIGENT AERAS™ TECHNOLOGY

In an increasingly complex world, smart devices simplify the intersection between technology and life. From the evolution of the smartphone to the smart home revolution, smart is simplifying the way we live, streamlining the way we work and enhancing the way we play. This interconnectivity gives us unmatched control over our environment.

GIVING A VOICE TO THE TOOLS OF THE TRADE

When the tools of your trade can communicate with each other, that's smart. When they can communicate with you, that's Aeras. The new Aeras platform from DENTALEZ can collect data, share information and streamline standard-of-care processes, creating an environment of patient care and practice efficiency that will revolutionize the way you interact with your dental office.



Industry-leading **39 watts** rivals the performance of electric with the confidence & safety of air



Maintain control with **in-office turbine replacements** to ensure readiness and maximum performance is always within reach



Greater in-hand **stability** with exceptional **balance** minimizes effort & fatigue



Exclusive **LubeFree** technology makes it easy to maintain control with in-office turbine replacements



Patent-pending **embedded RFID technology** can reduce the burden for office staff by automating tracking & recordkeeping*



500 ELITE HANDPIECE
Aeras
Star

STOP SETTLING FOR THE SILENT TREATMENT FROM YOUR HANDPIECE

*Disclaimer: when used in conjunction with a compatible RFID reader system

Aeras 500 Elite Handpieces are Made in the USA

Aeras Compressors

Aeras Dry Vacuums

Bison

Badger LF

Tanks

Wet Vacuums

Maintenance

OWL Touch

Remote Panels

Steel Frame Stands

Master Water Control Valve

Amalgam Separator

VACHECK FLOWCHECK

SlugBuster

Warranty

Sales Teams

Forest *EQUIPMENT*



Aeras
Compressors

Aeras
Dry Vacuums

Bison

Badger LF

Tanks

Wet Vacuums

Maintenance

OWL Touch

Remote Panels

Steel Frame
Stands

Master Water
Control Valve

Amalgam
Separator

VACHECK
FLOWCHECK

SlugBuster

Warranty

Sales Teams

Aeras
Compressors

Aeras
Dry Vacuums

Bison

Badger LF

Tanks

Wet Vacuums

Maintenance

OWL Touch

Remote Panels

Steel Frame
Stands

Master Water
Control Valve

Amalgam
Seperator

VACHECK
FLOWCHECK

SlugBuster

Warranty

Sales Teams

BRIGHTEN UP YOUR TREATMENT ROOM

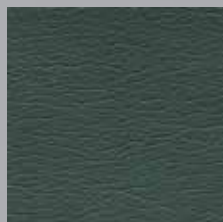

OZ
Ultraleather®



LEMANS
Carbon Fiber

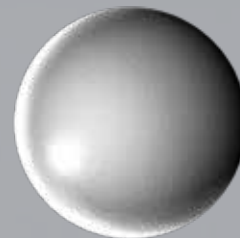

ARCTIC SILVER
Powdercoat Paint

Ramvac UTILITY



Aeras
Compressors

Aeras
Dry Vacuums

Bison

Badger LF

Tanks

Wet Vacuums

Maintenance

OWL Touch

Remote Panels

Steel Frame
Stands

Master Water
Control Valve

Amalgam
Separator

VACHECK
FLOWCHECK

SlugBuster

Warranty

Sales Teams

VACUUMS

100% WATER FREE OPERATION

– Saves money compared to wet vacuum designs

**ON BOARD SENSORS
& INTEGRATED CONTROL MONITORS**

– Monitors & communicates potential problems

6-YEAR WARRANTY

– 10-year for the pump

– Best in the industry

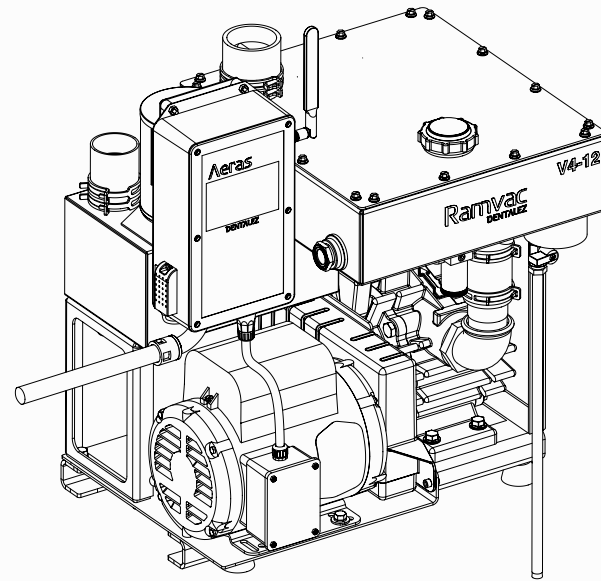

ROTARY VANE PUMP TECHNOLOGY

– Long-lasting & require minimal maintenance

COMPRESSORS

DUAL DESICCANT DRYER TECHNOLOGY

– Continuous dry air prevents bacterial growth

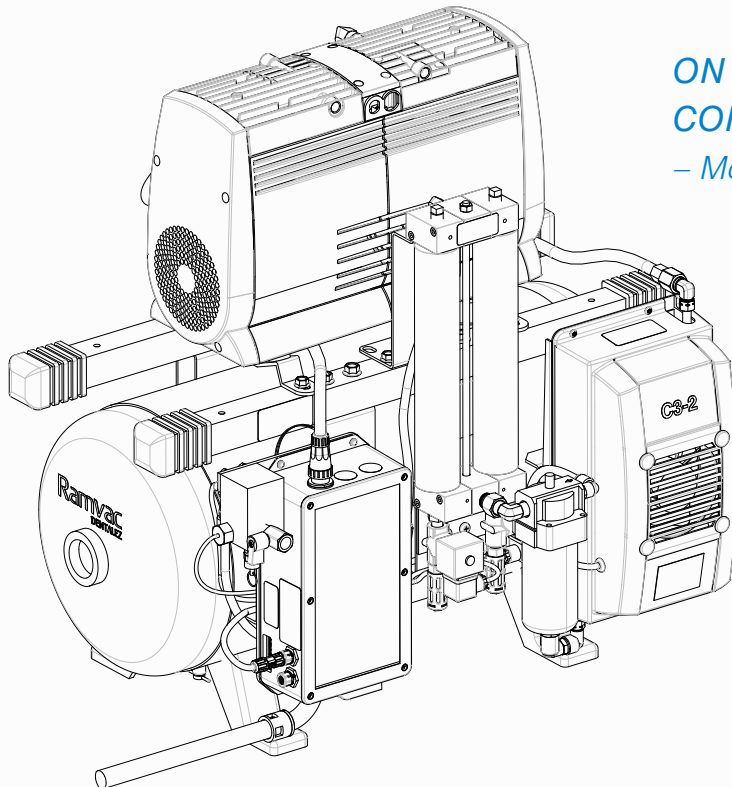

**ON BOARD SENSORS AND INTEGRATED
CONTROL MONITORS**

– Monitors & communicates potential problems

ROCKING PISTON DESIGN

– Reduces ambient noise while doubling
the life of the compression rings compared
to a standard piston design

6-YEAR WARRANTY

– Best in the industry

HIGH-PRESSURE MODE FOR MILLING MACHINES

– Easily choose between standard & high-pressure mode for milling machines

UTILITY
Aeras
Ramvac

Aeras
Compressors

Aeras
Dry Vacuums

Bison

Badger LF

Tanks

Wet Vacuums

Maintenance

OWL Touch

Remote Panels

Steel Frame
Stands

Master Water
Control Valve

Amalgam
Separator

VACHECK
FLOWCHECK

SlugBuster

Warranty

Sales Teams

Aeras^{UTILITY} Ramvac

INTELLIGENT UTILITY THAT
MONITORS & COMMUNICATES

Feel confident knowing your utility equipment
can be monitored & protected around the clock.¹

Service provider can view up to six months of
data to help diagnose potential issues.¹

8-Year optional extended warranty.*

Schedule exactly when your equipment
powers up & turns off.¹

Get automatic notification when preventive
maintenance is required.¹



Nomenclature Key

Series Name	Max Number of Users	Max Input Power
C = Ramvac® Compressor	3 = up to 3 users	1 = 115 volts
	4 = up to 4 users	2 = 230 volts
	6 = up to 6 users	
	7 = up to 7 users	
	11 = up to 11 users	

Electrical Requirements

Model Number	Description	Voltage	Amps	Break Size	Total HP
C3-2	Aeras™ 3 Compressor	230V	10.5	20 amp	2
C4-1	Aeras 4 Compressor	115V	23	30 amp	2.5
C4-2	Aeras 4 Compressor	230V	11.5	20 amp	2.5
C6-2	Aeras 6 Compressor	230V	16.3	20 amp	3.25
C7-2	Aeras 7 Compressor	230V	21	30 amp	4
C11-2	Aeras 11 Compressor	230V	32	40 amp	6

Weight and Dimensions

Model Number	Description	Weight (lbs)	Dimensions W x D x H (in)	Dimensions w Sound Cover	Tank Size (Gallon)
C3-2	Aeras 3 Compressor	160	29" x 21" x 29"	33.3" x 29" x 34"	12
C4-1	Aeras 4 Compressor	190	29" x 21" x 29"	33.3" x 29" x 34"	12
C4-2	Aeras 4 Compressor	190	29" x 21" x 29"	33.3" x 29" x 34"	12
C6-2	Aeras 6 Compressor	250	35" x 25" x 30"	35" x 29" x 34"	20
C7-2	Aeras 7 Compressor	260	35" x 25" x 30"	35" x 29" x 34"	20
C11-2	Aeras 11 Compressor	385	41" x 29" x 32"	41.1" x 33" x 36"	30

Sizing Guide

Model Number	Description	Number of Users	Number of Heads	Peak Airflow Output @ 80 PSI (CFM)	Sound Covers
C3-2	Aeras 3 Compressor	3	1	6.0	8543-022
C4-1	Aeras 4 Compressor	4	2	6.6	8543-021
C4-2	Aeras 4 Compressor	4	2	6.6	8543-022
C6-2	Aeras 6 Compressor	6	2	9.3	8543-023
C7-2	Aeras 7 Compressor	7	2	12.0	8543-023
C11-2	Aeras 11 Compressor	11	3	18.1	8543-024

NOTES:

Note for all compressors: Pressure is 85-115 PSI. High-Pressure Mode is 105-131 PSI.
Pump Up Cycle Time, 85 to 115 PSI (Sec) is 40-45.

*Terms apply.

¹ Applies only if subscribing to monitoring service

Aeras
Dry Vacuums

Bison

Badger LF

Tanks

Wet Vacuums

Maintenance

OWL Touch

Remote Panels

Steel Frame
StandsMaster Water
Control ValveAmalgam
SeparatorVACHECK
FLOWCHECK

SlugBuster

Warranty

Sales Teams

Aeras 3 Compressor

Part Number C3-2 Retail **\$8,374**

Aeras 3 Compressor
Aeras 3 Sound Cover for C3-2

C3-2 \$8,374
8543-022 \$1,904

Aeras Dry Vacuums

Aeras 4 Compressor

Part Number C4-1 Retail **\$8,374**

Aeras 4 Compressor
Aeras 4 Sound Cover for C4-1

C4-1 \$8,374
8543-021 \$1,904

Bison

Badger LF

Aeras 4 Compressor

Part Number C4-2 Retail **\$10,468**

Aeras 4 Compressor
Aeras 4 Sound Cover for C4-2

C4-2 \$10,468
8543-022 \$1,904

Tanks

Wet Vacuums

Aeras 6 Compressor

Part Number C6-2 Retail **\$11,601**

Aeras 6 Compressor
Aeras 6 Sound Cover for C6-2

C6-2 \$11,601
8543-023 \$1,904

Maintenance

OWL Touch

Aeras 7 Compressor

Part Number C7-2 Retail **\$13,177**

Aeras 7 Compressor
Aeras 7 Sound Cover for C7-2

C7-2 \$13,177
8543-023 \$1,904

Remote Panels

Aeras 11 Compressor

Part Number C11-2 Retail **\$17,670**

Aeras 11 Compressor
Aeras 11 Sound Cover for C11-2

C11-2 \$17,670
8543-024 \$2,380

Steel Frame Stands

Master Water Control Valve

Amalgam Separator

VACHECK FLOWCHECK

SlugBuster

Warranty

Sales Teams

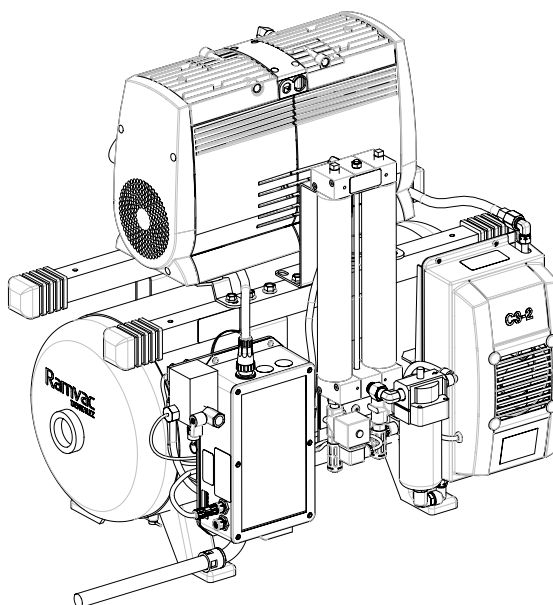

For your repair and maintenance needs, visit www.dentalezparts.com. See page 19 for maintenance parts.

Aeras^{UTILITY} Ramvac



COMING
SUMMER
2020

INTELLIGENT UTILITY THAT
MONITORS & COMMUNICATES

Feel confident knowing your utility equipment
can be monitored & protected around the clock.¹

Service provider can view up to six months of
data to help diagnose potential issues.¹

8-Year optional extended warranty.*

Schedule exactly when your equipment
powers up & turns off.¹

Get automatic notification when preventive
maintenance is required.¹

Nomenclature Key

Series Name	Max Number of Users	Max Input Power	Tank Included
V = Ramvac® Dry Vac	4 = up to 4 users	12 = 115v or 230v	T = tank included
	5 = up to 5 users	2 = 230v	
	7 = up to 7 users		
	10 = up to 10 users		

Electrical Requirements

Model Number	Description	Output Power	Input Power	Max Amps
V4-12T	Aeras™ 4 Dry Vacuum System	1 hp (0.745kW)	115v or 230v, 1 ph 60 Hz	9 @ 115v, 4.5 @ 230v
V5-2T	Aeras 5 Dry Vacuum System	3 hp (2.2kW)	230v, 1 ph 60 Hz	16.0 @ 230v
V7-2T	Aeras 7 Dry Vacuum System	3 hp (2.2kW)	230v, 1 ph 60 Hz	16.0 @ 230v
V10-2T	Aeras 10 Dry Vacuum System	3 hp (2.2kW)	230v, 1 ph 60 Hz	16.0 @ 230v

Weight and Dimensions

Model Number	Description	Weight (lbs) Pump only	Dimensions (Pump only) W x D x H (in)	Stacked Dimensions (Pump and Tank)
V4-12T	Aeras 4 Dry Vacuum System	200 lbs	21" x 17" x 28"	25" x 19" x 44"
V5-2T	Aeras 5 Dry Vacuum System	345 lbs	26" x 19" x 30"	32" x 21" x 58"
V7-2T	Aeras 7 Dry Vacuum System	345 lbs	26" x 19" x 30"	32" x 21" x 58"
V10-2T	Aeras 10 Dry Vacuum System	395 lbs	26" x 22" x 30"	32" x 22" x 58"

Sizing Guide

Model Number	Description	Users	Breaker Size	Drain Valve Centerline to Floor
V4-12T	Aeras 4 Dry Vacuum System	4	15 amp	8"
V5-2T	Aeras 5 Dry Vacuum System	5	20 amp	8"
V7-2T	Aeras 7 Dry Vacuum System	7	20 amp	8"
V10-2T	Aeras 10 Dry Vacuum System	10	20 amp	8"

NOTES:

All Aeras Vacuum systems (pump and tank) include a platform (5705056) for stacking.
Height dimensions do not include S-type filters.

*Terms apply.

¹ Applies only if subscribing to monitoring service

Aeras 4 Dry Vacuum System

Part Number	Retail
V4-12T	\$12,791

Vacuum System (with 15g tank)

Aeras 4 Dry Vacuum System 4 User/115V & 230V Single Phase	V4-12T	\$12,791	_____
--	--------	----------	-------

Vacuum Only

Aeras 4 Dry Vacuum 4 User/115V & 230V Single Phase	V4-12	\$11,591	_____
---	-------	----------	-------

Aeras 5 Dry Vacuum System

Part Number	Retail
V5-2T	\$15,737

Vacuum System (with 15g tank)

Aeras 5 Dry Vacuum System 5 User 230V Single Phase	V5-2T	\$15,737	_____
---	-------	----------	-------

Aeras 7 Dry Vacuum System 7 User 230V Single Phase	V7-2T	\$18,204	_____
---	-------	----------	-------

Aeras 10 Dry Vacuum System 10 User 230V Single Phase	V10-2T	\$22,787	_____
---	--------	----------	-------

Aeras 7 Dry Vacuum System

Part Number	Retail
V7-2T	\$18,204

Vacuum Only

Aeras 5 Dry Vacuum 5 User 230V Single Phase	V5-2	\$14,537	_____
--	------	----------	-------

Aeras 7 Dry Vacuum 7 User 230V Single Phase	V7-2	\$17,004	_____
--	------	----------	-------

Aeras 10 Dry Vacuum 10 User 230V Single Phase	V10-2	\$21,587	_____
--	-------	----------	-------

Aeras 10 Dry Vacuum System

Part Number	Retail
V10-2T	\$22,787

TOTAL _____

For your repair and maintenance needs,

visit www.dentalezparts.com.

See page 19 for maintenance parts.

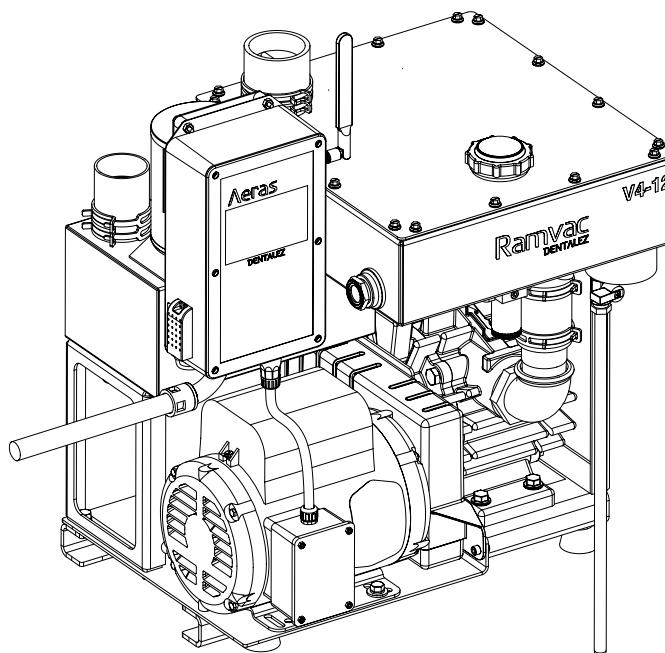

Bison®



Easy ordering with system part numbers:

B = Bison

T = with Tank

Numerical Number =
Number of Users

-3 = 3 Phase, 230V
(if applicable)

-3-460 = 3 Phase, 460V
(if applicable)

Badger™ LF



The efficient, LubeFree dry vacuum system

- Compact LubeFree rotary vane pump with integrated 5 gallon tank
- Dental office can transition easily from wet to dry vacuum
- Open frame design means quick maintenance
- Saves 200,000 gallons of water annually
- 5 gallon polyethylene tank
- 2 year system warranty and 5 year pump warranty

Standard Features

Bison Specifications

Product Name	Bison 5	Bison 7	Bison 9
Tank	15 Gallon	15 Gallon	30 Gallon
Users	7	10	12
Power Requirements			
Output Power	3 hp (2.2kW)	3 hp (2.2kW)	5 hp (3.7kW)
Input Power	B5T7-3 230v, 3 ph 60 Hz	B7T10-3 230v, 3 ph 60 Hz	B9T12-3 230v, 3 ph 60 Hz
	B5T7-3-460 460v, 3 ph 60 Hz	B7T10-3-460 460v, 3 ph 60 Hz	B9T12-3-460 460v, 3 ph 60 Hz
Max Amps	B5T7-3 8.4@230v	B7T10-3 8.4@230v	B9T12-3 13.2@230v
	B5T7-3-460 4.2@460v	B7T10-3-460 4.2@460v	B9T12-3-460 6.6@460v
Dimensions (pump only)			
W	26"	26"	26"
D	19"	22"	22"
H	30"	30"	30"
Stacked Dimensions (pump & tank)			
W	32"	32"	32"
D	21"	22"	22"
H	58"	58"	70"
Breaker Size	B5T7-3 15 amp	B7T10-3 15 amp	B9T12-3-460 15 amp
	B5T7 20 amp	B5T10 20 amp	B9T12-3 20 amp

Badger Specifications

Power Requirements	Pump Specifications		
Users	4	HP	1.5 HP 1,200 rpm
Voltage	208-230 VAC, Single Phase	Weight	Unit: 175lbs Shipping: 195lb
Full Load	6.2A	Maximum Vacuum	15 in Hg
Frequency	60 Hz	Breaker Size	15amp
Exhaust Vent	2"		
Dimensions:	W25"xD18"xH24"		

Options

Bison 5

System (pump & tank) 230v, ph3	Part No	Retail	Price
	B5T7-3	\$19,574	_____
Vacuum (pump only) 230v, ph3	818E.1050.3	\$17,633	_____
System (pump & tank) 460v, ph3	B5T7-3-460	\$19,574	_____
Vacuum (pump only) 460v, ph3	818E.1050.3	\$17,633	_____

Bison 7

System (pump & tank) 230v, ph3	B7T10-3	\$23,986	_____
Vacuum (pump only) 230v, ph3	826E.0800.3	\$22,027	_____
System (pump & tank) 460v, ph3	B7T10-3-460	\$23,986	_____
Vacuum (pump only) 460v, ph3	826E.0800.3	\$22,027	_____

Bison 9

System (pump & tank) 230v, ph3	B9T12-3	\$25,853	_____
Vacuum (pump only) 230v, ph3	826E.1050.3	\$23,736	_____
System (pump & tank) 460v, ph3	B9T12-3-460	\$25,853	_____
Vacuum (pump only) 460v, ph3	826E.1050.3	\$23,736	_____

Badger LF

Dry Vacuum	BADGLF2	\$10,987	_____
		TOTAL	_____

NOTES:

All Bison systems (pump and tank) include a platform (57056) for stacking.
Drain Valve Centerline to Floor: 8" Height dimensions do not include S-type filters.
E2 control not compatible with OWL.

Tanks

InfiniTank®

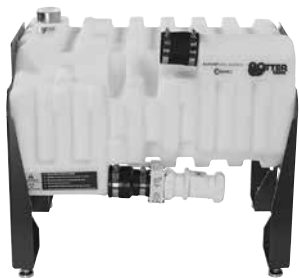

15 Gallon



30 Gallon

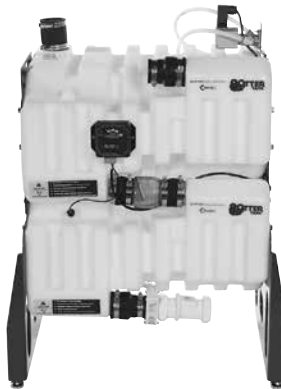

InfiniTank



50 Gallon Cylindrical Tank

Standard Features

Tanks

- Store liquids and debris removed from the treatment room
- Tanks must be sized to correctly match the volume of liquids and debris removed during a vacuum operating cycle.

Specifications	15 Gallon	30 Gallon
Treatment Rooms*	1-6	7-12
W	25"	29"
D	20"	20"
H	24"	36"

Options

Tanks

- 15-Gallon Tank
- 30-Gallon Tank

Additional Options

- Bison Platform
- Suspension Set
- 12" Height Extender
- Auxiliary Vacuum Adapter

Part No

Retail

Price

InfiniTanks

InfiniTanks

- Simple maintenance free design
- Drains without vacuum interruption
- Significantly reduces the size and number of separating tanks
- Completely automated to provide worry free operation

Specifications	InfiniTank	InfiniTank-High Flow
Treatment Rooms*	1-20	1-20
W	29"	55"
D	21"	27"
H	38"	62"

50 Gallon Cylindrical Tank

50 Gallon Cylindrical Tank

- Easy to Install
- Reliable
- Fiberglass construction won't corrode
- Clean-drain tapered bottom
- Clog resistant drain valve
- Omni-directional drain & pump connections

Specifications

Treatment Rooms*	13-20
Includes	2" & 3" inlet & vacuum fittings, 3 each galvanized pipe legs, and drain valve
OD	24"
H	62"

NOTES:

* This assumes 1 chair per room. For bays, let "rooms"= chairs.

Barracuda™

• 100% Dual Redundancy

- Brass impeller and housing with sealed motor bearings for long life and chemical resistance
- 1 & 2 HP Water Injected Pump models available to meet a practice's specific requirements
- Optional water recirculator reduces water consumption by about 75%
- Two independent pumps to handle peak loads and back-up protection (Dual only)
- Maintains vacuum in peak work periods (Dual only)
- Provides back-up protection to minimize downtime (Dual only)
- Now with a 5 year limited warranty from date of installation.

Barracuda Single

Product Name	Barracuda CV-101FS	Barracuda CV-101FSW	Barracuda CV-102FS	Barracuda CV-102FSW
Recirculator	N/A	Included	N/A	Included
Horsepower	1x1 HP	1x1 HP	1x2 HP	1x2 HP
Volts	115 / 208-230	115 / 208-230	208-230	208-230
Amps (each motor)	13.2 / 7.2-6.6	13.2 / 7.2-6.6	11.9-10.7	11.9-10.7
Phase	Single	Single	Single	Single
RPM	3450	3450	3450	3450
Ambient Temperature	32°C / 104°F	32°C / 104°F	32°C / 104°F	32°C / 104°F
Cycle	60 Hz	60 Hz	60 Hz	60 Hz
Width	12"	12"	14"	14"
Depth	9"	9"	11"	11"
Height	16"	16"	20"	20"
Shipping Weight	68 lbs.	68 lbs.	78 lbs.	78 lbs.
Typical application	2 Users	2 Users	3 Users	3 Users
Breaker Size	20 amp	20 amp	20 amp	20 amp
Max sealed vacuum	Approximately 20-25 inches Hg Adjustable			

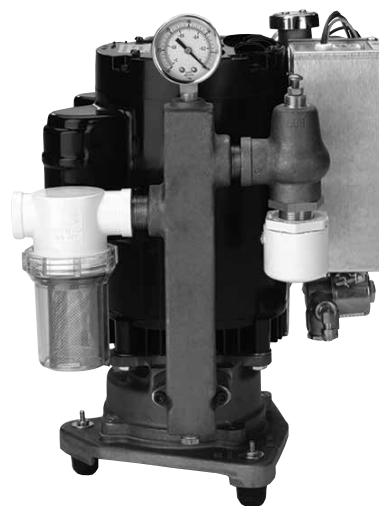

Barracuda CV-101FS

Barracuda Dual

Product Name	Barracuda MC-201FS	Barracuda MC-201FSW	Barracuda MC-202FS	Barracuda MC-202FSW
Recirculator	N/A	Included	N/A	Included
Horsepower	2 x 1 HP	2 x 1 HP	2 x 2 HP	2 x 2 HP
Volts	208-230	208-230	208-230	208-230
Amps (each motor)	7.5 each motor	7.5 each motor	15 each motor	15 each motor
Phase	Single	Single	Single	Single
RPM	3450	3450	3450	3450
Ambient Temperature	32°C / 104°F	32°C / 104°F	32°C / 104°F	32°C / 104°F
Cycle	60 Hz	60 Hz	60 Hz	60 Hz
Width	24"	26"	24"	26"
Depth	17"	20"	17"	20"
Height	24"	24"	24"	24"
Shipping Weight	175 lbs.	175 lbs.	215 lbs.	215 lbs.
Typical application	4 Users	4 Users	6 Users	6 Users
Breaker Size*	15 amp	15 amp	20 amp	20 amp
Max sealed vacuum	Approximately 20-25 inches Hg Adjustable			

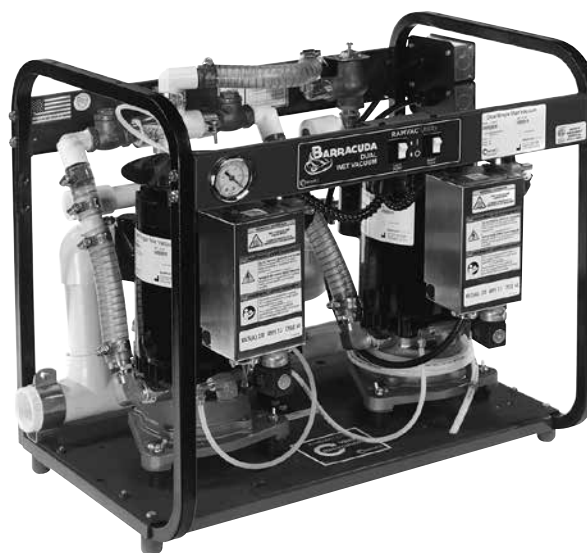

**Barracuda MC-202FSW
(with optional water recirculator)**

NOTES:
Dimensions do not include recirculator
*Each motor.

Aeras
Compressors

Aeras
Dry Vacuums

Bison

Badger LF

Tanks

Wet Vacuums

Maintenance

OWL Touch

Remote Panels

Steel Frame
Stands

Master Water
Control Valve

Amalgam
Separator

VACHECK
FLOWCHECK

SlugBuster

Warranty

Sales Teams



Barracuda CV-101FS

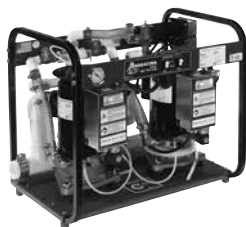

Barracuda MC-202FSW



NEW STYLE WITH RELAY BOX
For use with wet pumps with serial numbers starting with "V"



OLD STYLE NO RELAY BOX
For use with wet pumps with serial numbers starting with "S"

Barracuda Single

Barracuda CV-101FS	64586121	\$3,351	_____
Barracuda CV-101FSW	64586121W	\$3,834	_____
Barracuda CV-102FS	64586122	\$4,155	_____
Barracuda CV-102FSW	64586122W	\$4,552	_____

Barracuda Dual

Barracuda MC-201FS	64586110D	\$7,008	_____
Barracuda MC-201FSW	6458611DW	\$7,411	_____
Barracuda MC-202FS	64586211D	\$8,266	_____
Barracuda MC-202FSW	6458621DW	\$8,714	_____

Water Recirculators

WR-100 - Water Recirculator for CV-101	64592011	\$786	_____
WR-100 - Water Recirculator for CV-102	64592012	\$786	_____
WR-100 - Water Recirculator for MC-201 & MC-202 Pumps	64592005	\$958	_____
Cleaner for Water Recirculator (Case of 48)	64568129	\$158	_____

Water Separator

AM-200 - Air/Water or Nitrous Oxide Separator	64656200	\$612	_____
---	----------	-------	-------

Maintenance / Replacement Pumps*

MC-201FS 1 HP	64586811R	\$2,863	_____
MC-202FS 2 HP	64586812R	\$3,328	_____
MC-201FS with Water Recirculator	64586813R	\$2,883	_____
MC-202FS with Water Recirculator	64586814R	\$3,348	_____
MC-201 Old Style-208/230 Volt (no relay box)	64586100R	\$2,615	_____
MC-202 Old Style-208/230 Volt (no relay box)	64586200R	\$2,830	_____

Accessories

Top shelf with a 300 lb. Capacity for Stacking Compressors	64568202	\$202	_____
--	----------	-------	-------

TOTAL _____

For your repair and maintenance needs,
visit www.dentalezparts.com.



Compressor Maintenance

Filter Maintenance Kit for 3 - 4 user Compressor, includes 1 coalescing filter, 1 particulate filter, 2 intake filters	005147SP	\$250	_____
Filter Maintenance Kit for 6 user Compressor, includes 1 coalescing filter, 1 particulate filter, 2 intake filters	005350SP	\$287	_____
Filter Maintenance Kit for 7 user Compressor, includes 1 coalescing filter, 1 particulate filter, 2 intake filters	005148SP	\$313	_____
Filter Maintenance Kit for 11 user Compressor, includes 1 coalescing filter, 1 particulate filter, 2 intake filters	005149SP	\$360	_____
Fresh Air Intake Kit for 3 - 7 user Compressor	005002	\$310	_____
Fresh Air Intake Kit for 11 user Compressor	005014	\$391	_____
Service Part, Dryer HR2 for 3 & 4 user Compressor	004018SP	\$688	_____
Service Part, Dryer HR4 for 6 & 7 user Compressor	004020SP	\$1,227	_____
Service Part, Dryer HR4L for 11 user Compressor	005413SP	\$1,266	_____
Maintenance Kit for 1022 Compressor; includes 1 intake filter, 1 coalescing filter, and 1 particulate filter	004415	\$347	_____
Maintenance Kit for 1013D, 1023D, 1025D and 1027D20 Compressor; includes 2 intake filters, 1 coalescing filter, and 1 particulate filter	004016	\$365	_____
Maintenance Kit for 1029T and 1029T30 Compressor; includes 3 intake filters, 1 coalescing filter, and 1 particulate filter	004017	\$380	_____

For your repair and maintenance needs, visit www.dentalezparts.com.



Vacuum Maintenance

Air Filter Set for 4 user Vacuum, includes main air filter and vacuum controller filter	003583	\$156	_____
Oil Filter Element	310705	\$55	_____
Service Filter Set for 4 user Vacuum, includes main air filter, vacuum control filter and oil filter element	003740	\$210	_____
Air Filter set for 5-12 user Vacuum, includes main air filter & vacuum controller fan	003700	\$210	_____
Oil Filter Element	310705	\$55	_____
User Service Filter set for 5-12 user Vacuum, includes main air filter, vacuum control filter and oil filter elements	003750	\$263	_____
Ramvac Synthetic Oil, 6 x 1qt. bottles	7809-001	\$151	_____
"Standard" Air Filter Set, includes Main Air Filter & Vacuum Controller Filter	710720	\$73	_____
Pump Oil, DELVAC 15W40 Pack of 4 gal for models 550, 1400 and 2800	310703	\$164	_____





25 Micron Filter Element (for units prior to serial number: BG1307xxx)	004691SP	\$52	_____
Badger Service Filter Set (for units later than serial number: BG1307xxx (requires both filters))	005301SP	\$95	_____

TOTAL _____

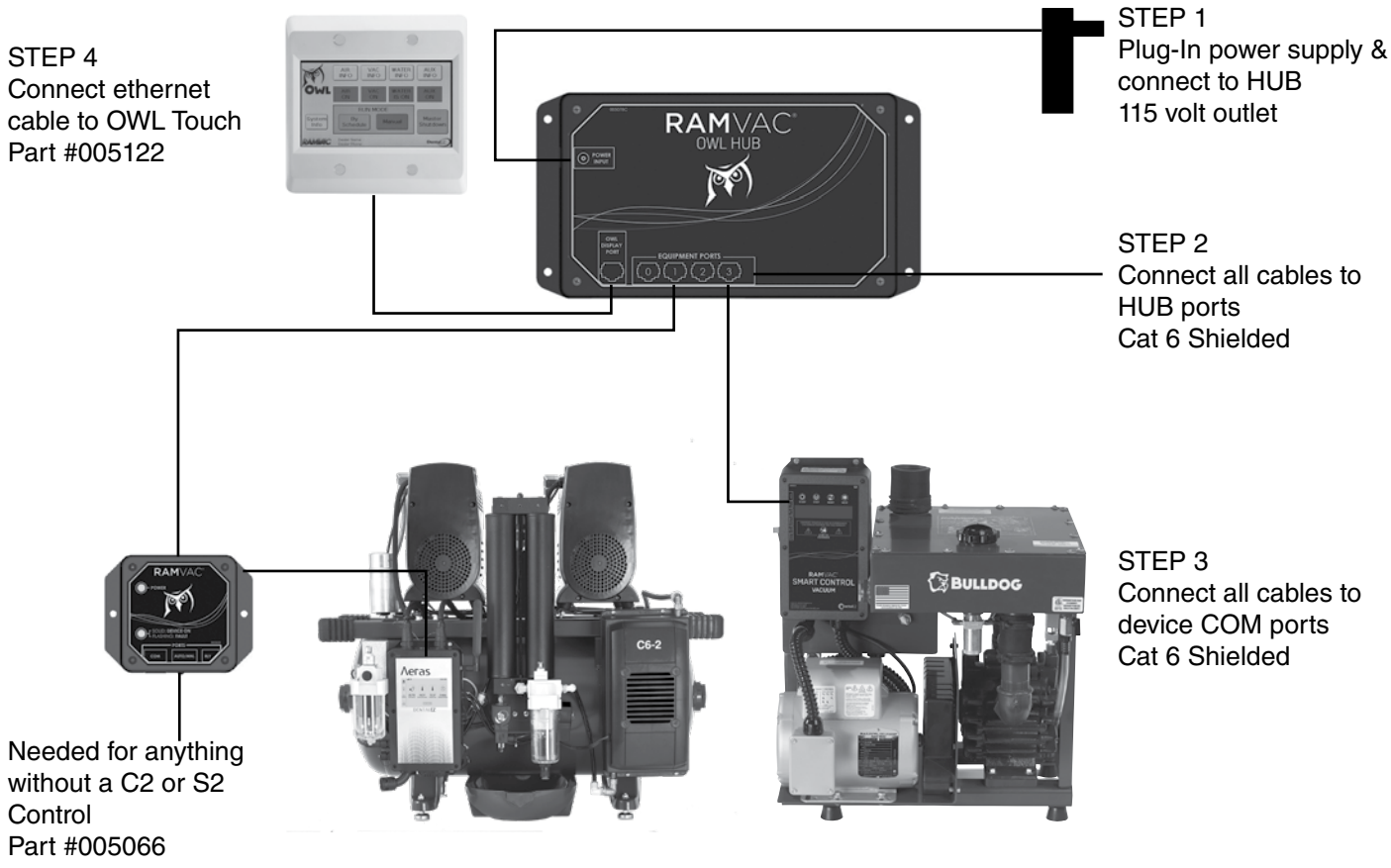
OWL™ Touch - On Wall Logic



Standard Features	Options	Part No	Retail	Price
OWL Touch	OWL Touch			
	OWL Touch 4	005122	\$1,843	_____
	OWL Touch 8	005123	\$3,082	_____
	OWL Touch 16	005124	\$4,525	_____
	OWL Interface Control (required for non C2 / S2)	005066	\$439	_____
	OWL Touch Options			
	OWL Hub Mounting Bracket (mounts to Ramvac Utility Stand)	005155	\$153	_____
	7' Cat6 shielded, green, each	005088	\$16	_____
	14' Cat6 shielded, green, each	005089	\$18	_____
	25' Cat6 shielded, green, each	005090	\$27	_____
	50' Cat6 shielded, green, each	005091	\$118	_____
	100' Cat6 shielded, green, each	005092	\$172	_____
	Note: Does not include cables			
Remote Panels	Remote Panels			
	Remote Panel #1	8-600-131	\$313	_____
	Remote Panel #2	8-600-132	\$508	_____
	Remote Panel #3	8-600-133	\$659	_____
	Remote Panel #4	8-600-134	\$817	_____
	TOTAL			_____

Aeras Compressors

Aeras Dry Vacuums

Bison

Badger LF

Tanks

Wet Vacuums

Maintenance

OWL Touch

Remote Panels

Steel Frame Stands

Master Water Control Valve

Amalgam Separator

VACHECK FLOWCHECK

SlugBuster

Warranty

Sales Teams

Master Water Control Valve



NOTES:
Master Water Control Valves now come standard with 24V Solenoid valve and transformer for easy installation to Ramvac master control panels. 115V versions are available; please call 1-866-DTE-INFO for ordering information and availability.

Master Water Control Valves

Master Water Control Valve adjustable between 1/2" and 3/4"

MWC075 \$1,522

Master Water Control Valve adjustable between 1/2" and 3/4" with regulator

MWC075R \$1,991

Master Water Control Valve 1"

MWC001 \$2,192

Replacement Cartridges

AP110 Water Filter for 1/2" and 3/4" Master water controls (2 pack, for older WC series)

64520006 \$96

AP801 Water Filter for 1" Master water controls (2 pack, for older WC series)

64520012 \$258

Filter Cartridge Kit for new MWC series (2 pack)

8801-040 \$171

Master Water Control Valve Replacement Kits

Solenoid Valve Kit, 3/4"

8801-041 \$496

Solenoid Valve Kit, 1"

8801-042 \$629

Transformer Kit

8801-043 \$91

O-Ring Replacement Kit

8801-044 \$47

Buck / Boost Transformers

UP TO 40A CIRCUIT

192 - 197V

64637020 \$2,150

91 - 94V, 198 - 205V

64637019 \$1,608

94 - 98V, 206 - 212V

64637013 \$1,745

UP TO 20A CIRCUIT

94 - 98V, 206 - 212V

64637006 \$611

Adapters

Auxiliary Vacuum Adapter

590504 \$123

TOTAL

Aeras Dry Vacuums

Bison

Badger LF

Tanks

Wet Vacuums

Maintenance

OWL Touch

Remote Panels

Steel Frame Stands

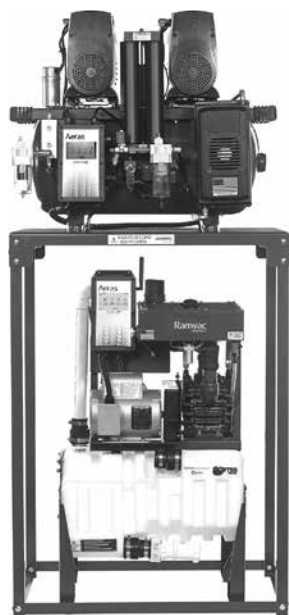

NOTES:
The Aeras 11 Compressor (C11-2) with sound cover does not fit underneath either utility stand.

Steel Frame Stands

Utility Stand 36"W x 24"D x 40"H

160040 \$885

Utility Stand 36"W x 24"D x 50"H

160050 \$921

OWL Hub Mounting Bracket (mounts to either stand above)

005155 \$153

Steel Frame Stands

Master Water Control Valve

Amalgam Separator

VACHECK FLOWCHECK

SlugBuster

Warranty

Sales Teams

Amalgam Separator

VACHECK® / FLOWCHECK®

SlugBuster™

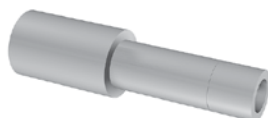

VACHECK for Simple
"Pass-Fail" indication.
(Patent 5,779,472)



FLOWCHECK for
measurement
of flow in SCFM.
(Patent 6,925,886 B2)



Standard Features

NXT Amalgam Separator

- Compact design from Solmetex with internal manifold, ideal for hard to fit areas
- Integrates seamlessly with all Ramvac wet and dry vacuums
- Environmentally friendly packaging
- Simple mail-back recycling program
- Meets all "EPA Dental Rule" requirements
 - Clear system, easy to inspect
 - Two-minute container change out
 - No tools necessary
- ISO 11143 certified by NSF International

NOTES:

Replacement canisters are supplied by Solmetex, to order, please contact them directly. Used collection containers must be delivered to an EPA Certified Recycler. Ramvac is not a recycler. Do NOT send used collection containers to Ramvac.

Options

Hg5 Models

- NXT Hg5 Amalgam Separator (1-10 users)
- NXT Hg5 MINI Amalgam Separator (1-4 users)
- NXT Hg5 High Volume Amalgam Separator (11-20 users)

Additional Options

- Bracket Mount to Ramvac Otter Tank

Part No

Retail

Price

VACHECK / FLOWCHECK

Check the vacuum performance for your treatment room.

VACHECK

800500

\$52

FLOWCHECK

800501

\$819

SlugBuster™

Cleans and deodorizes vacuum hoses, drains, piping, and separators.

SlugBuster

Powder Starter Pack includes a 2 gallon mixing jug, two 40oz. containers of SlugBuster powder with scoop

900143

\$145

Powder 6 Pack includes six 40oz. containers of SlugBuster powder with scoop

900146

\$281

Liquid Single Gallon includes a single gallon of SlugBuster concentrate and hand pump dispenser

900241

\$81

Liquid Starter Pack includes 2 gallon mixing jug, 1 gallon of SlugBuster concentrate, and hand pump dispenser

900243

\$145

Liquid 4 Pack Case includes 4 single gallons of SlugBuster concentrate and 4 hand pump dispensers

900246

\$258

NOTES:

Please refer to your User Guide or contact Ramvac Technical Support to determine your Ramvac's oil capacity.

TOTAL

Ramvac Product Support Services

DENTALEZ and its employees are proud of the products we provide to the dental community. We stand behind these products with a warranty against defects in material and workmanship as provided below and have our own in-house repair facility to service our products. In the event that you experience difficulty with the application or operation of any of our products, please contact our customer service department at our expense at (866)DTE-INFO.

If we cannot resolve the issue by telephone, we will arrange for a representative to contact you or suggest that the product be returned to our factory for inspection.

If product return or repair is required, we will provide you with a Return Authorization number and shipping instructions to return the product to the proper facility. If the product is under warranty, we will ask you to provide proof of purchase such as a copy of your invoice. Please be sure to include the Return Authorization number on the package you are returning. Products returned without a return authorization number cannot be repaired.

Freight costs for product returns are the responsibility of the customer. Products under warranty will be repaired or replaced, at our sole discretion, and returned at our expense. Products outside the warranty limits will be repaired and returned with costs invoiced to the customer. We are not responsible for shipping damages. We will, however, help you file a claim with the freight carrier. Written repair estimates are available.

DENTALEZ warrants all equipment and parts to be free of defects in material and workmanship, under normal usage, under the following terms:

Ramvac

Limited Warranty Period*

Aeras Compressors	6 Years / 4,200 hours from date of installation (whichever comes first)
Aeras Dry Vacuums	6 Years, 10 years for rotary vane pump from date of installation
Aeras Compressors and Vacuums with Aeras Smart Monitoring Service	8 years from date of installation for Aeras compressors or dry vacuums, 8 years/5,600 hours (whichever comes first) for Aeras compressors provided the following additional terms applicable to this 2 year extended warranty are met: - Aeras Smart Monitoring Service must be continuously maintained throughout the eight (8) year warranty period. - Aeras Compressor must be serviced and maintained by DENTALEZ or by an authorized DENTALEZ dealer in accordance with DENTALEZ maintenance schedule and as provided in the manual - Only genuine Ramvac parts are used for all repairs and maintenance
Wet Vacuum Systems	5 Years from date of installation
Bulldog and Bison Dry Vacuum Systems	2 Years from date of installation
Rotary Vane Pumps (Bulldog and Bison Only)	10 Years from date of installation
Osprey Compressors	6 Years / 4,200 hours from date of installation (whichever comes first)
OWL Touch	2 Years from date of installation
Badger LF Vacuum System	2 Years from date of installation
Badger LF Pump only	5 Years / 10,000 hours from date of installation (whichever comes first)
Master Water Control	2 Years from date of installation
NXT Hg5 Amalgam Separator	Warranty from Solmetex, 2 years

Please note the following additional terms of our warranty and return policy:

- This warranty covers manufacturing defects only and does not cover defects resulting from abuse, accidents, misuse, improper handling, cleaning, care or maintenance. Damage resulting from the use of chemicals, cleaners, disinfectants or sterilization is not covered under this warranty nor is normal wear and tear. Failure to follow or observe our operating/use, maintenance and/or installation instructions voids this warranty as does the use of non-authorized parts and repairs made by an unauthorized repair facility.
- Liability is limited to repair or replacement of the defective part(s) or products at our sole discretion. All other liabilities, in particular liability for damages, including, without limitation, special, exemplary, consequential or incidental damages are excluded.
- This warranty is in lieu of all other warranties, expressed or implied, including ANY IMPLIED warranties of merchantability or fitness for a particular purpose. no employee, representative or dealer is authorized to change this warranty in any way or to grant any other warranty.

Warranty Repairs:

Parts repaired or replaced on a product that is in warranty will be warranted for the duration of that product's original warranty.

Product Returns:

Opened products or product returns more than a year old cannot be returned for credit. There will be a 15% (\$25.00 minimum) restocking charge on all items authorized for return.

NOTES:

*Provided conditions defined in instruction manual are met. Aeras is a trademark and DENTALEZ is a registered trademark of DENTALEZ, Inc. Ramvac, Bison, Bulldog, FLOWCHECK, InfinitiTank, Otter, Ramclean and VACHECK are registered trademarks and Badger, Barracuda, Osprey, OWL, and SlugBuster are trademarks of Ramvac Dental Products, Inc.

INTERNATIONAL, DENTAL SERVICE ORGANIZATIONS, SCHOOLS & GOVERNMENT SALES

Special Markets Managers (SMM)

*NORTHEAST TERRITORY:
STEVEN SIDMORE, SMM*

ssidmore@dentalez.com
Maine, New Hampshire, Vermont, Massachusetts,
Rhode Island, Connecticut, New York, New Jersey,
Pennsylvania, Delaware, Maryland, Canadian Provinces:
Quebec, New Brunswick & Nova Scotia

*SOUTHEAST TERRITORY:
RYAN O'BERRY, SMM*

roberry@dentalez.com
Washington DC, Ohio, West Virginia, Virginia, North
Carolina, South Carolina, Eastern Tennessee, Georgia,
Florida & Alabama

*NORTHCENTRAL TERRITORY:
DUSTIN STEMBER, SMM*

dstember@dentalez.com
913.972.4963
Minnesota, Iowa, Missouri, Wisconsin, Michigan, Illinois,
Indiana, Kentucky, Canadian Province: Ontario

*CENTRAL TERRITORY:
BRIAN KENNEDY, SMM*

bkennedy@dentalez.com
214.673.3475
North Dakota, South Dakota, Nebraska, Kansas,
Oklahoma, Texas, Louisiana, Arkansas, Mississippi &
Eastern Tennessee

*SOUTHWEST TERRITORY:
CHAD PRICE, SMM*

cprice@dentalez.com
805.245.4315
Wyoming, Nevada, Utah, Colorado, Southern
California (SD), Arizona, New Mexico,
Texas - El Paso Area, Hawaii, Alaska
& International - Military

*PACIFIC NORTHWEST:
JIM ZANN, SMM*

jzann@dentalez.com
916.835.2804
Washington, Oregon, California, Idaho, Montana,
Canadian Provinces: British Columbia, Alberta,
Saskatchewan & Manitoba

Sales Leadership

*DIRECTOR OF SALES
INTERNATIONAL/SPECIAL MARKETS*

Carlos Martinez
484.983.9026
cmartinez@dentalez.com

*SPECIAL MARKETS ACCOUNT EXEC.
AGGIE PENNINGTON*

C 484.433.8980
O 610.725.8004 ext. 1338
apennington@dentalez.com

Lab Sales

*SR. INSTITUTIONAL SALES MANAGER
NEVINLABS*

JASON HODKOWSKI
708-466-8220
jhodkowski@dentalez.com

*NEVIN SALES SPECIALIST
NORTHERN US*

DON TOMKO
484-401-1427
dtomko@dentalez.com

*NEVIN SALES SPECIALIST
SOUTHERN US*

WILL KING
980.428.1777
wking@dentalez.com

Aeras
Compressors

Aeras
Dry Vacuums

Bison

Badger LF

Tanks

Wet Vacuums

Maintenance

OWL Touch

Remote Panels

Steel Frame
Stands

Master Water
Control Valve

Amalgam
Separator

VACHECK
FLOWCHECK

SlugBuster

Warranty

Sales Teams

PRIVATE PRACTICE & DEALER SALES

Professional Sales Associates

MICHEL CABANIE

mcabanie@profsales.com
514.793.3368 (C)
Quebec, Nova Scotia,
New Brunswick & Ottawa

STEVE CARLIN

scarlin@profsales.com
952.491.1223 (C)
MN, SD, NE, ND, IA

SKIP ELLENDER

sellender@profsales.com
617.894.1224 (C)
AZ, NM, Southern WY, CO
El Paso, TX

RICH ELLIS

rellis@profsales.com
301.502.7424 (C)
MD, VA, WV, DC

MIKE GULLAGE

mgullage@profsales.com
205.529.0243 (C)
GA (except Savannah & Valdosta)
AL, East TN, Pensacola, FL

BILL HIGHLAND

bhighland@profsales.com
810.623.7297 (C)
MI, OH, IN

MATT HIGHLAND

mhighland@profsales.com
901.606.3633 (C)
New Orleans, LA, MS, Memphis
TN, Nashville, TN, Little Rock, AR, KY

BRETT HOBBS

bhobbs@profsales.com
630.772.4321 (C)
Northern and Central IL, WI

MATT LANGDON

mlangdon@profsales.com
516.316.5913 (C)
Greater New York City, Westchester
& Long Island, NY, Northern & Central NJ

MILTON LORRING

mlorring@profsales.com
216.396.2341 (C)
OH, Western PA, Buffalo,
Syracuse & Rochester, NY, WV

STEVE MARBLE

smarble@profsales.com
413.636.5897 (C)
CT, MA, ME, NH, RI, VT
Newburgh, Albany

JOHN MILLER

jmiller@profsales.com
503.758.9895 (C)
OR, WA, Northern ID, MT
Northern WY, AK

STEPHAN NUGENT

snugent@profsales.com
214.394.0074 (C)
Northern TX, OK, Fayetteville
AR, Shreveport, LA

KEITH O'BERRY

koberry@profsales.com
336.210.1429 (C)
NC, SC, Savannah, GA

RICK ORME

rorme@profsales.com
916.837.3839 (C)
Northern CA, NV
(except Las Vegas), HI

SAM PAOLA

spaola@profsales.com
310.569.1178 (C)
Southern CA, Southern ID,
UT, Las Vegas, NV

AARON RENNER

arenner@profsales.com
519.319.7457 (C)
Ontario (except Ottawa) & MB

ROBERT RODRIGUEZ

rrodriguez@profsales.com
305.458.6538 (C)
FL, Valdosta, GA & PR

DON ROGERS, LLL

drogers@profsales.com
717.201.7332 (C)
Eastern PA, Southern NJ, DE

SCOTT RUMBLE

srumble@profsales.com
403-801-5390 (C)
Southern TX

JIM SCHLOSSER

jschlosser@profsales.com
909.215.3277 (C)
Southern CA, Southern ID, UT
Las Vegas, NV

SHAWN SILVEY

ssilvey@profsales.com
314.249.6052 (C)
KS, MO, Southern IL

VICTOR YOON

vyoon@profsales.com
778-688-8429 (Cell)
British Columbia, Alberta
& Saskatchewan

Sales Leadership

LOU GUELLNITZ

DENTALEZ
Director of Sales, Dental
lguellnitz@dentalez.com
484.473.3788

Aeras
Compressors

Aeras
Dry Vacuums

Bison

Badger LF

Tanks

Wet Vacuums

Maintenance

OWL Touch

Remote Panels

Steel Frame
Stands

Master Water
Control Valve

Amalgam
Separator

VACHECK
FLOWCHECK

SlugBuster

Warranty

Sales Teams

